

May 2, 1933.

T. R. ARDEN

1,907,379

TOY TYPEWRITER

Filed Sept. 19, 1932

4 Sheets-Sheet 1

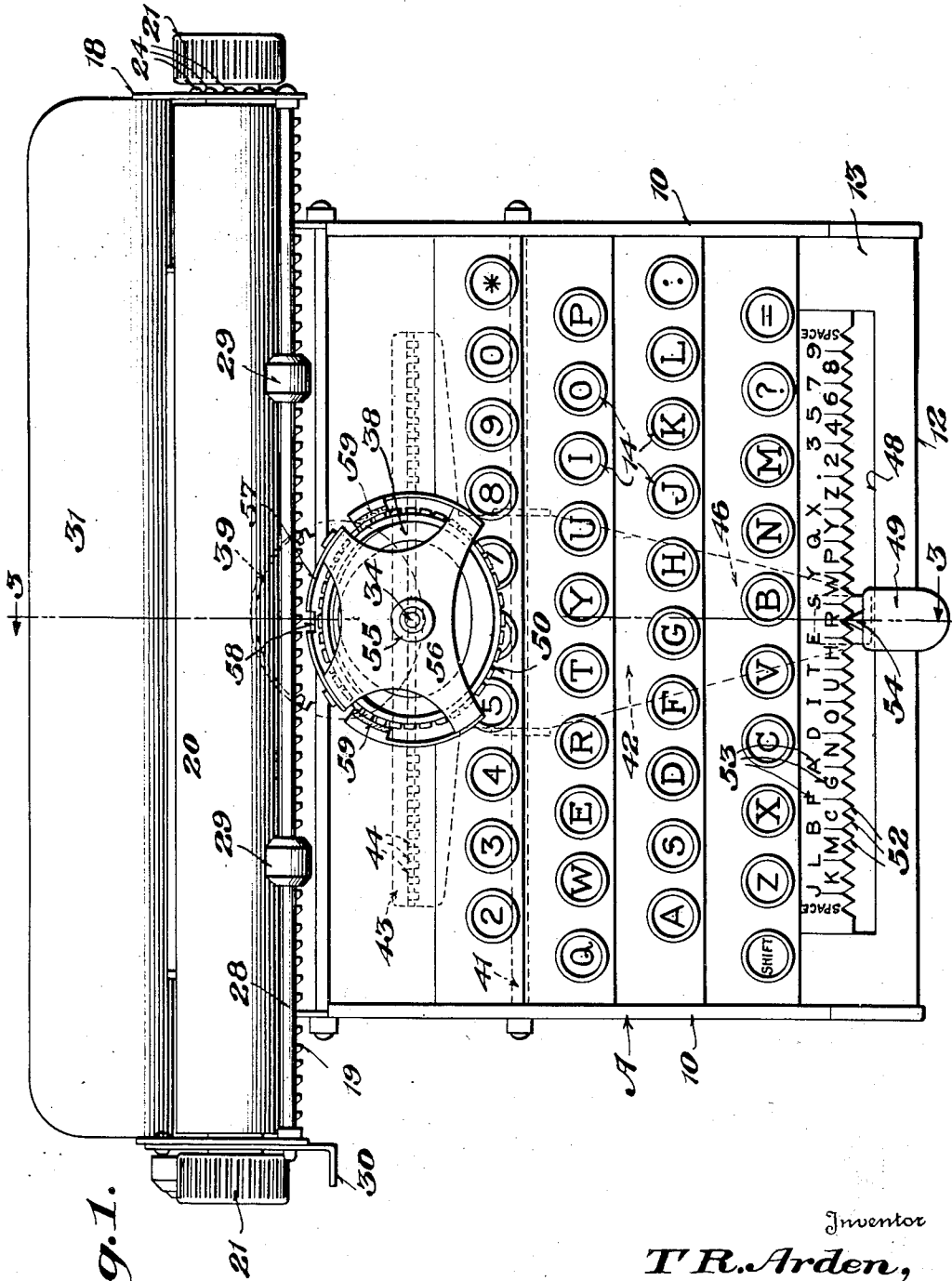

Fig. 1.

Inventor

T. R. Arden,

A. P. Wellhauser

By

Attorney

May 2, 1933.

T. R. ARDEN

1,907,379

TOY TYPEWRITER

Filed Sept. 19, 1932

4 Sheets-Sheet 2

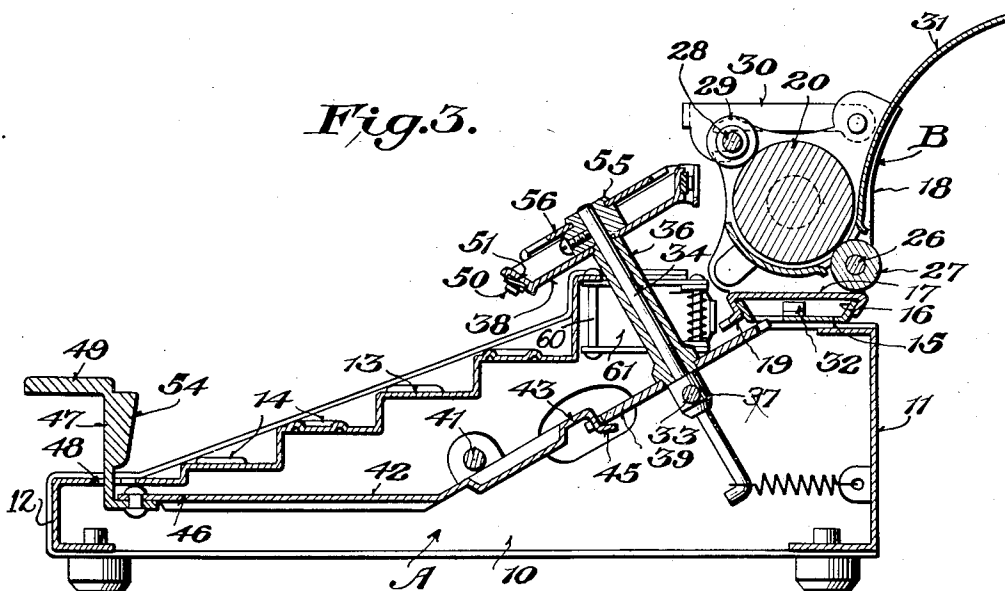
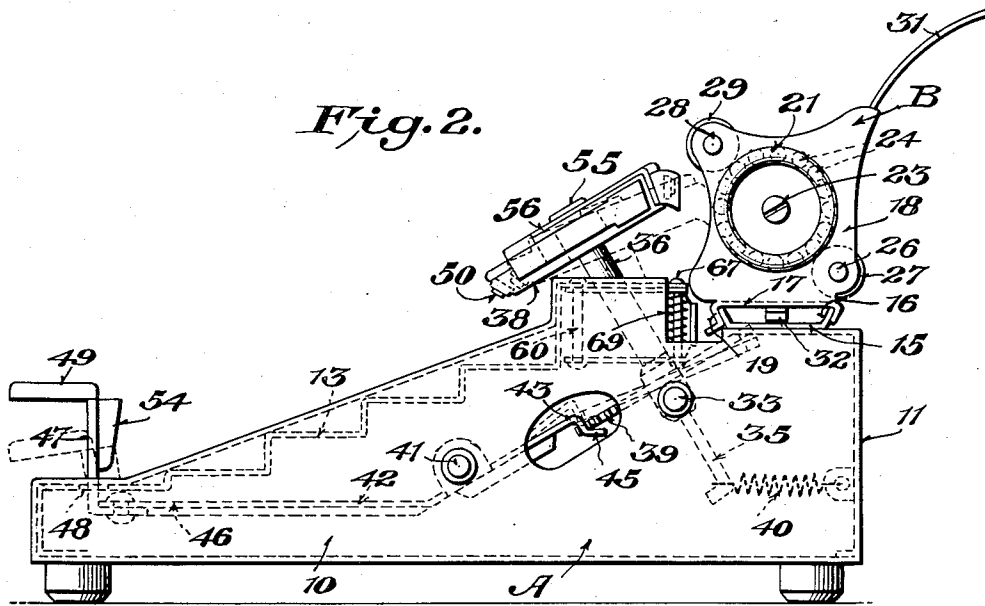

Inventor

T. R. Arden,

S. P. Wilkerson

Attorney

May 2, 1933.

T. R. ARDEN

1,907,379

TOY TYPEWRITER

Filed Sept. 19, 1932

4 Sheets-Sheet 3

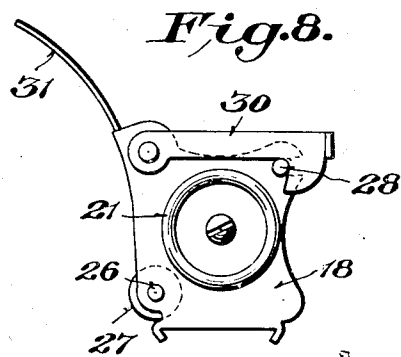
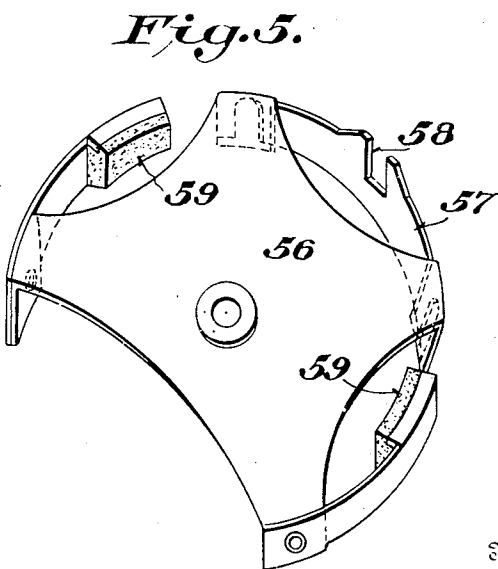
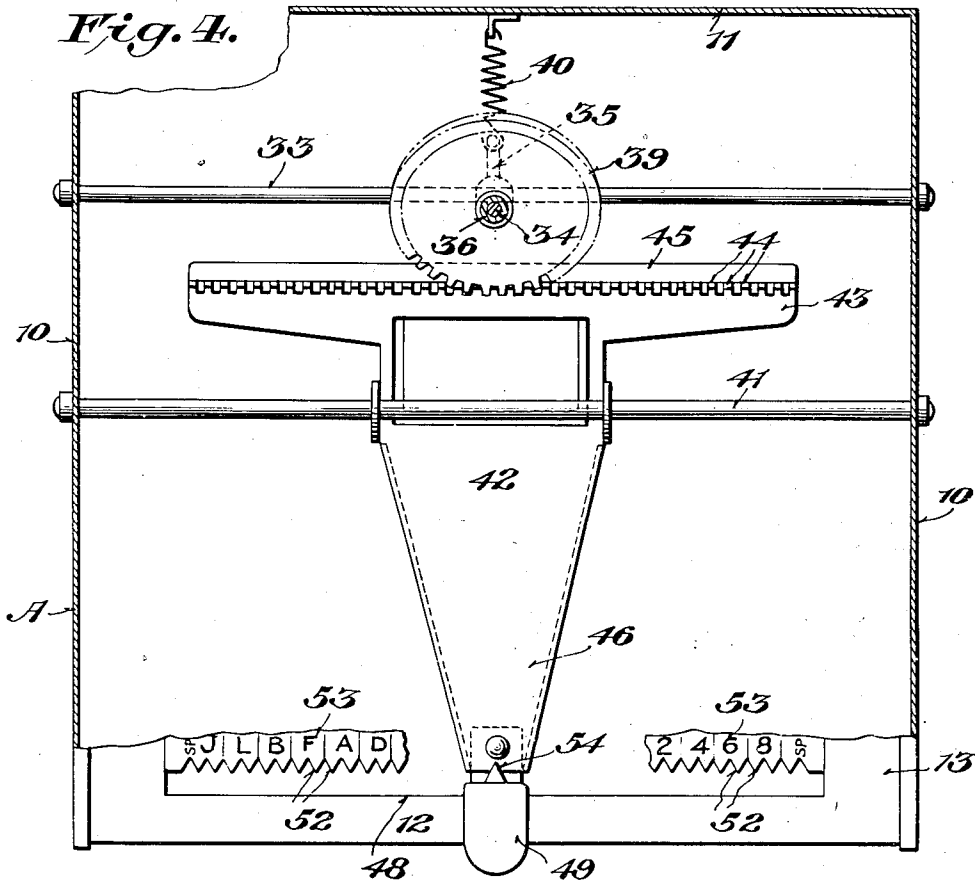

Inventor

T. R. Arden,

St. Willhauser

Attorney

May 2, 1933.

T. R. ARDEN

1,907,379

TOY TYPEWRITER

Filed Sept. 19, 1932

4 Sheets-Sheet 4

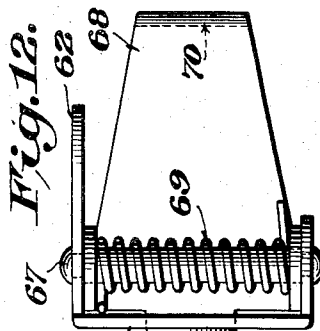
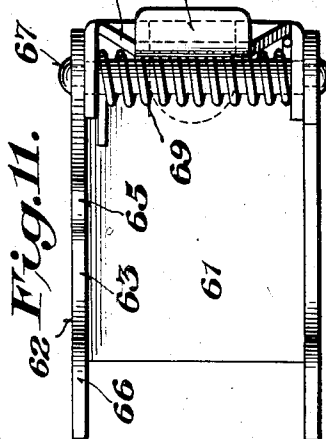
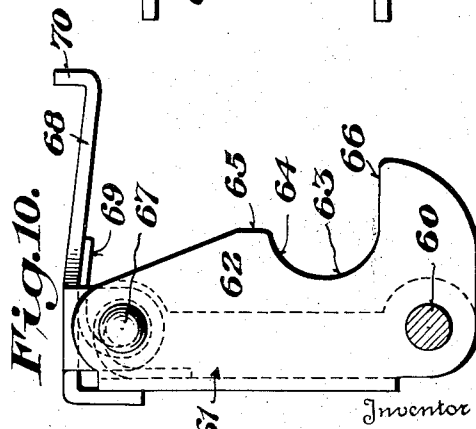
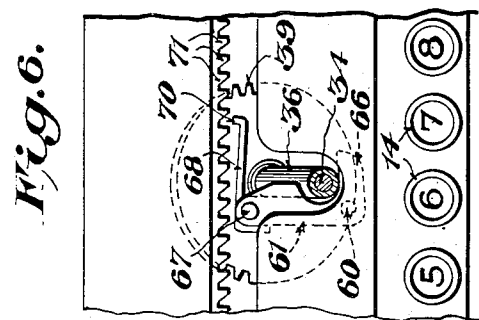
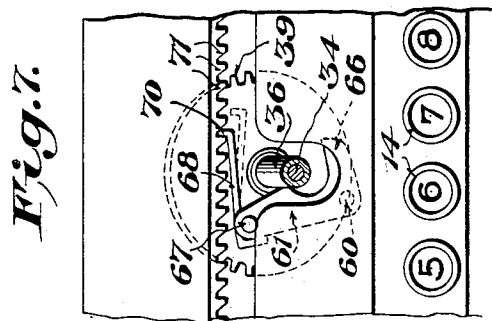
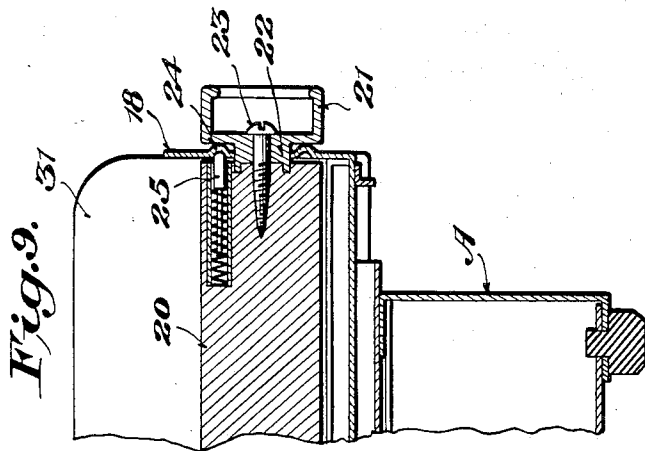

Inventor
T. R. Arden,

(Signature)

Attorney

UNITED STATES PATENT OFFICE

THOMAS RAYMOND ARDEN, OF BALDWIN, NEW YORK, ASSIGNOR TO AMERICAN FLYER MFG. CO., OF CHICAGO, ILLINOIS, A CORPORATION OF ILLINOIS

TOY TYPEWRITER

Application filed September 19, 1932. Serial No. 633,865.

This invention relates to typewriters, and has particular reference to a typewriter which is intended primarily to be manufactured, sold and used as a toy, but which at the same time, embodies a construction and mode of operation adapting the same for practical use.

A special object of the invention is to provide a typewriter which closely simulates ordinary commercial typewriters in general appearance, but which is composed of relatively few parts which may be economically produced and assembled, whereby the typewriter is of comparatively low production cost.

Another object of the invention is to provide a typewriter having a novel construction and mode of operation, and which, in addition to being of comparatively low production cost, is compact, strong and durable, and thoroughly reliable and efficient in operation.

With the foregoing and various other objects in view, which will become more fully apparent as the nature of the invention is better understood, the same consists in the novel features of construction, combination and arrangement of parts as will be hereinafter more fully described, illustrated in the accompanying drawings and defined in the appended claims.

In the drawings, wherein like characters of reference denote corresponding parts in the different views:—

Figure 1 is a top plan view of a typewriter constructed in accordance with the invention.

Figure 2 is a side elevation.

Figure 3 is a central cross section.

Figure 4 is a plan view with the platen and its carriage removed and with parts broken away to disclose the underlying structure.

Figure 5 is a perspective view of the type guard.

Figure 6 is a detail view showing the step-by-step platen advancing means in normal position.

Figure 7 is a view similar to Fig. 6 showing the platen advancing means in a platen advancing position.

Figure 8 is a detail end view of the platen carriage.

Figure 9 is a detail sectional view through one end of the platen and its carriage; and

Figures 10, 11 and 12 are detail views of the platen advancing pawl.

Referring in detail to the practical embodiment of the invention illustrated in the drawings, A designates, generally, a hollow frame which may be cast, but which, preferably is pressed or otherwise suitably formed from sheet metal, either in one piece or in a plurality of pieces, and which is composed, as shown, of side walls 10, a rear wall 11, a front wall 12 and a top wall 13.

The frame A is of suitable length and width and is of greatest height at its rear, being of gradually reduced height from a point spaced suitably forward from its rear wall to the front thereof, and having its top wall 13 formed as a series of steps on which are suitably provided simulations 14 of the keys of an ordinary typewriter, whereby a relatively close general simulation of the appearance of an ordinary typewriter is obtained.

Suitably fixed to the top wall 13 of the frame A at the rear thereof is an elongated guide 15 which extends longitudinally of the frame and which is formed preferably from a strip of sheet metal having upwardly and outwardly flared marginal flanges 16.

A platen carriage, designated generally as B, and composed of a bottom wall 17 and end walls 18, is mounted on the guide 15 for sliding movement therealong and is retained in assembly with the frame A by having marginal portions 19 of its bottom wall 17 flanged downwardly and inwardly for cooperation with the guide flanges 16.

A platen 20 in the form of a cylinder of any suitable material extends longitudinally of the carriage B and is rotatably mounted on said carriage in any suitable manner, as, for example, by means of knobs 21 which have hub portions 22 journaled in openings in the end walls 18 of the carriage and which are secured to the ends of the platen as by means of screws 23, said knobs providing means for manually rotating the platen.

In one of the end walls 18 of the carriage B is formed a circular series of depressions 24 concentric with the axis of rotation of the platen and evenly spaced apart corresponding to the amount of rotation of the platen necessary to advance a sheet of paper an amount corresponding to a desired spacing between lines of the matter to be typed, while mounted within a recess in the platen and projecting beyond the end thereof for cooperation with said depressions 24 is a spring pressed friction pin 25. Obviously, the pin 25 permits manual rotation of the platen to advance a sheet of paper, but serves by becoming seated first in one and then in another of the depressions 24 to predetermine the increments of rotation of the platen and to yieldably hold the same against rotation.

At the rear of the platen 20 and mounted on a rod or shaft 26 which is journaled at its ends in the end walls 18 of the carriage B is a paper guide roller 27, while at the front of the platen and mounted on a rod or shaft 28 which also is journaled at its ends in the end walls of the carriage is one or more paper guide rollers 29. One of the end walls of the carriage is slotted to receive the related end of the rod or shaft 28 so that said rod may be swung outwardly to move the roller or rollers 29 away from the platen to facilitate the introduction of a sheet of paper between the platen and the roller or rollers 29, while pivoted to said end wall is a hook 30 for engagement with said rod or shaft 28 to hold the same engaged in said slot.

A sheet metal paper guide plate 31 is secured between the end walls 18 of the carriage B and extends beneath the platen 20 in slight spaced relation thereto and thence upwardly and rearwardly so as to support a sheet of paper in operative position relative to the platen, and said plate is slotted as shown to accommodate the guide roller 27. Moreover, a resilient friction member 32 is carried either by the carriage B for engagement with the guide 15, or by the guide for engagement with the carriage, to resist endwise movement of the carriage, thus to hold the same normally against such movement.

A shaft 33 extends longitudinally of the frame A and is journaled at its ends in the side walls 10 thereof, and on this shaft is mounted for forward and backward rocking movement a transverse, upwardly and forwardly inclined shaft 34 having an extension 35 which projects downwardly below said shaft 33.

Rotatably mounted on the shaft 34 is a sleeve 36 which rests at its lower end on a collar or abutment 37 carried by said shaft and which has fixed thereto at its upper end a type wheel 38, and, at its lower end, a gear wheel 39.

The shaft 34 is disposed midway between the sides of the frame A and directly in front of the platen 20, being so spaced therefrom that the type wheel 38 is normally spaced a short distance from the platen so as to be swung thereagainst when the shaft 34 is rocked rearwardly.

Normally the shaft 34 is maintained by a coil spring 40 in a forwardly rocked position in which the type wheel 38 is spaced from the platen 20, said coil spring being connected at one end to the extension 35 of said shaft 34 and at its other end to the rear wall of the frame A.

Another shaft 41 extends longitudinally of the frame A in front of the shaft 33 and, as in the case of the latter shaft, is journaled at its ends in the side walls 10 of the frame. Suitably mounted on this shaft 41 for sliding movement therealong and also for rocking movement relative thereto is a lever 42 having an elongated rear end portion 43 formed with rack teeth 44 for cooperation with the teeth of the gear wheel 39. Said portion 43 also is formed with a marginal, rearwardly directed lip 45 which underlies the front portion of said gear wheel 39 so as to serve, when the said rear end portion of the lever 42 is swung upwardly, to effect upward tilting of the front of the gear wheel thus to tilt the shaft 34 rearwardly to cause the type wheel 38 to be swung against the platen.

The lever 42 is inclusive of a forwardly extending portion 46 which, at its front end, is extended upwardly as at 47 through a longitudinally extending slot 48 in the top wall 13 of the frame A, and thence forwardly in the form of a finger engageable manipulating element 49. Obviously, by exerting lateral pressure on the element 49 the lever 42 may be shifted along the rod or shaft 41 to effect rotation of the gear wheel 39 and consequently of the type wheel 38, while by depressing said element 49 the lever obviously may be rocked on the shaft 41 to effect rocking of the type wheel rearwardly against the platen.

The type wheel 38 may have type formed directly thereon. Preferably, however, the type characters 50 are formed separately from said wheel and are detachably secured thereon whereby they may be individually or collectively renewed whenever desired. The type wheel may, for example, be formed with a peripheral groove or channel as illustrated and the type characters may be formed on an elastic band 51 to be frictionally or otherwise retained in said groove or channel. In any event, the type characters are spaced circumferentially around the type wheel and project from the periphery thereof so that by rotation of the type wheel any desired character may be brought to a rearmost position whereby subsequent rearward rocking movement of the type wheel causes the selected

character to impinge against a sheet of paper extending across the front of the platen.

By particular reference to Fig. 1 of the drawings it will be observed that the edge of the top wall 13 defining the rear edge of the slot 48 is provided with a series of notches 52 and that printed or otherwise provided on the top wall 13 is a series of characters 53, one alined with each notch. The characters 50 on the type wheel 38 correspond to the characters 53, and the gear connection between the type wheel and the lever 42 provided by the rack teeth 44 and the gear wheel 39 is such that by laterally shifting the lever to aline a lug 54 thereon with the notch alined with any one of the characters 53 a proper amount of rotation is imparted to the type wheel to bring the corresponding type character 50 of the wheel to a rearmost position. Thus, the lever 42 serves both as a selector of the type characters to be printed and as a means of effecting printing movement of the type character against a sheet extending across the front of the platen.

Because of the engagement of the gear wheel 39 with the lip 45 of the lever 42 the spring 40 obviously functions to maintain the rear end of said lever normally depressed and the front end thereof normally elevated, and in this connection it will be noted that the lower end of the lug 54 is spaced above the notched edge of the top wall 13 of the frame A when the lever is in its normal position, whereby no interference is offered by said lug to free lateral sliding movement of the lever along the rod or shaft 41. However, upon depression of the lever the lug enters one or another of the notches and thereby serves not only to assure accuracy in rotation of the type wheel to bring any particular character to a printing position, but also to hold the type wheel against rotation during its rocking movement.

Suitably mounted on the shaft 34, as for example, by means of a collar 55 detachably fixed thereto, is a type guard 56 having a portion 57 which overlies the rear peripheral portion of the type wheel 38 and which has a recess 58 formed therein for the projection of the individual type characters 50 therethrough. This portion 57 of the guard is disposed normally outwardly relative to the type characters 50 so as to permit free rotation of the type wheel, but is resilient so that upon rearward rocking movement of the shaft 34 it is, by engagement with a sheet extending across the front of the platen, depressed forwardly to permit the type to project through the recess 58 therein into engagement with the sheet. The guard thus serves to prevent any printing by other than the selected character 50. Moreover, said guard constitutes a support for one or more absorbent ink pads or brushes 59 which is or are disposed to have the characters 50 wipe

thereagainst during rotation of the type wheel thus to supply said characters with ink to be transferred to the sheet.

The invention includes means whereby rocking movement of the shaft 34 effects a step-by-step longitudinal advance of the platen for the purpose of evenly spacing the successively printed characters. Referring particularly to Figs. 3, 6, 7 and 10 to 12 of the drawings, it will be observed that a vertical pivot pin 60 depends from the top wall 13 of the frame A at the left hand side of the shaft 34 as viewed in Figs. 6 and 7 and that mounted at its front end on said pivot pin for lateral swinging movement is a sheet metal member 61 of preferably U-shaped cross section which extends rearwardly from said pin and has a lateral flange 62 in the edge of which is formed a notch 63 which accommodates the sleeve 36 when the shaft 34 is in its normal forwardly rocked position. From the notch 63 the edge of the flange 62 is curved rearwardly and across the back of the sleeve 36, as indicated at 64, thereby to provide a cam surface against which the sleeve engages during the first part of its rearward rocking movement to cause the member 61 to be swung laterally and to the left on the pivot pin 60, while from the cam surface 64 said edge of the flange is extended rearwardly in an approximately straight line, as indicated at 65, so that the final portion of the rearward rocking movement of the sleeve maintains the member in its rocked position without imparting further rocking movement thereto. On the other hand, the edge of the flange 62 forwardly of the notch 63 is extended across the front of the sleeve 36 as at 66, so that upon forward rocking movement of the sleeve the same engages the edge 66 and swings the member 61 to its normal position. Thus, it is manifest that each time the shaft 34 is rocked rearwardly the member 61 is swung first laterally to the left and is returned to its normal position when the shaft 34 is rocked forwardly.

Pivoted as at 67 to the rear or free end of the member 61 is a pawl 68 which is urged constantly rearwardly by a spring 69 and which is provided at its free end with a hook formation 70 for cooperation with ratchet teeth 71 formed along an outwardly directed extension of the front carriage flange 19. Thus, during the first part of the rearward rocking movement of the shaft 34 the pivotal movement imparted to the member 61 produces a longitudinal movement of the pawl 68 to the left with consequent advance of the platen carriage and the platen to the left an amount which is predetermined to correspond to the proper spacing apart of the printed characters. This platen movement occurs prior to actual contact of the type 50 with the platen and is completed just prior to such contact so that as the type strikes the platen

the latter is stationary and any blurring of the printed character thereby is avoided. Upon forward rocking movement of the shaft 34 the member 61 is swung to the right and returned to its normal position by engagement of the sleeve 36 with the edge 66, and at the same time the pawl 68 is moved to the right and idles over the next tooth 71 so as to be in a position to engage said tooth to move the platen carriage another step to the left when the shaft 34 again is rocked rearwardly.

In the use of the typewriter a sheet of paper is inserted downwardly between the rear of the platen 22 and the paper guide plate 31 and by rotation of the platen is caused to be advanced thereunder between the platen and the feed roller 27. The paper is guided upwardly by the bottom portion of the plate 31 across the front of the platen and is readily engaged between the platen and the roller or rollers 29 by lifting the latch 30, swinging the shaft 28 outwardly, introducing the paper between the platen and the roller or rollers and subsequently returning the shaft 28 to and latching it in its normal position. When a sheet of paper thus has been operatively engaged with the platen the typewriter is ready for use, and writing on the paper is effected as follows:—The element 49 is grasped and is moved to the right or to the left as may be necessary to bring the lug 54 into alinement with the desired character 53 to be printed. This results, because of the engagement of the rack teeth 44 with the gear wheel 39, in rotation of the type wheel 38 to bring the corresponding type character 50 on the type wheel to a rearmost or operative position relative to the platen 20. The element 54 then is depressed and, because of the engagement of the lip 45 with the front of the gear wheel 39, produces rearward rocking movement of the shaft 34, the sleeve 36 and the type wheel. During the first part of this rearward rocking movement the platen is longitudinally advanced one step to the left by the pawl 68 as heretofore explained, and immediately thereafter further depression of the element 54 causes the selected type character 50 to strike the sheet of paper extending across the front of the platen. The element 54 then is released and the type wheel is rocked forwardly and the lever 42 is returned to its normal position by the spring 40. When, by repeating this operation, a line of typing has been completed, the platen is manually returned to its starting position and is rotated a desired amount to effect the desired spacing between lines, and the selection and printing of the characters on the new line is continued as before.

Without further description it is thought that the features and advantages of the invention will be readily apparent to those skilled in the art, and it will of course be understood that changes in the form, proportion and

minor details of construction may be resorted to, without departing from the spirit of the invention and scope of the appended claims.

I claim:—

1. A typewriter comprising a platen, a type wheel mounted adjacent to the platen for rotation to bring a selected type character into operative position relative to the platen, said type wheel also being mounted for rocking movement to cause the selected type character to strike the platen, a gear wheel fixed with respect to said type wheel, and an intermediately pivoted and laterally slidable lever having a rack engaging said gear whereby lateral sliding movement of the lever is effective to rotate the type wheel, said lever further having a formation cooperating with said gear so that pivotal movement of the lever is effective to rock the gear and thereby to rock the type wheel.

2. A typewriter comprising a platen, a type wheel mounted adjacent to the platen for rotation to bring a selected type character into operative position relative to the platen, said type wheel also being mounted for rocking movement to cause the selected type character to strike the platen, a gear wheel fixed with respect to said type wheel, and an intermediately pivoted and laterally slidable lever having a rack engaging said gear whereby lateral sliding movement of the lever is effective to rotate the type wheel, said lever further having a lip extending contiguous to said rack and underlying the gear so that pivotal movement of the lever is effective to rock the gear and thereby to rock the type wheel.

3. In a typewriter, a frame, a platen carriage, a platen carried by said carriage, a type wheel rotatable to bring a selected type character into operative position relatively to the platen and rockable to cause the selected type character to strike the platen, means for rotating and rocking said type wheel, a carriage guide comprising a metal strip mounted on the frame and having upwardly and outwardly directed marginal flanges, the carriage having downwardly and inwardly directed marginal flanges engaging said guide flanges, one of said carriage flanges having an extension provided with ratchet teeth, and a pawl mounted on the frame for actuation by rocking movement of the type wheel to cooperate with said teeth to advance the carriage and the platen.

4. In a typewriter, a platen carriage having ratchet teeth, a platen carried thereby, a type carrier, a type carrier supporting element rockable to actuate the type carrier to cause the type characters thereof to strike the platen, and means whereby rocking movement of the type wheel supporting element effects longitudinal movement of the carriage, said means comprising a pivoted cam member disposed to be swung by wip-

ing movement of the type carrier supporting element thereagainst during rocking thereof, and a pawl pivoted to said cam member and disposed for cooperation with the teeth of the carriage.

5
10
15
20
25
5. A typewriter comprising a platen, a type carrier operable by one kind of movement to bring a selected type character into operative position relative to the platen and by a different kind of movement to cause the selected type character to strike the platen, an element fixed with respect to said type carrier, a single operating member constantly operatively engaged with said element and having two different kinds of movement, and means whereby said member is operable directly through said element by one of its kinds of movement to impart one of the movements to the type carrier to bring a selected type character into operative position, and also is operable directly through said element by its other kind of movement to cause a change in the relative positions of the element and member whereby the other kind of movement is imparted to the type carrier to cause the selected type character to strike the platen.

6. A typewriter as set forth in claim 5 in which the type carrier and the element fixed with respect thereto have rotatable and rockable movements, and in which the operating member has lateral and rocking movements effective respectively to impart the aforesaid movements to the type carrier.

35
40
7. A typewriter as set forth in claim 5 in which the type carrier and the element fixed with respect thereto have rotatable and rockable movements, and in which the operating member is bodily movable to impart rotation to said element and type carrier and pivotally movable to impart rocking movement to said element and type carrier.

8. In a typewriter, a frame, a platen carriage, a platen carried by said carriage, a type wheel rotatable to bring a selected type character into operative position relatively to the platen and rockable to cause the selected type character to strike the platen, means for rotating and rocking said type wheel, carriage guides formed of sheet metal comprising a plurality of slidably interfitting flanges extending upwardly from the frame and downwardly from the carriage, respectively, one of said carriage flanges having ratchet teeth formed thereon, and a pawl mounted on the frame for actuation by rocking movement of the type wheel to cooperate with said teeth to advance the carriage and the platen.

60
In testimony whereof I hereunto affix my signature.

THOMAS RAYMOND ARDEN.